

Driver _____ Date _____ Track _____ Event _____

Track Condition

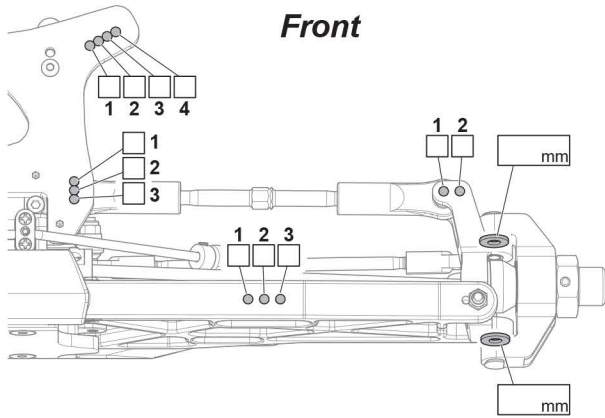

Front

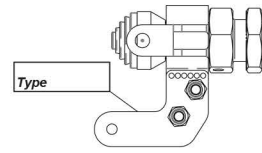

Type _____

Body Brand _____

Body Model _____

Ride Height _____ mm

Camber Angle _____ °

Toe Angle _____ °

Sway Bar _____ mm

Shock Length _____ mm

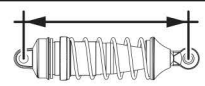

Front Shocks

Oil weight _____ wt

Piston _____ mm

Bladder _____

Spring _____

Notes

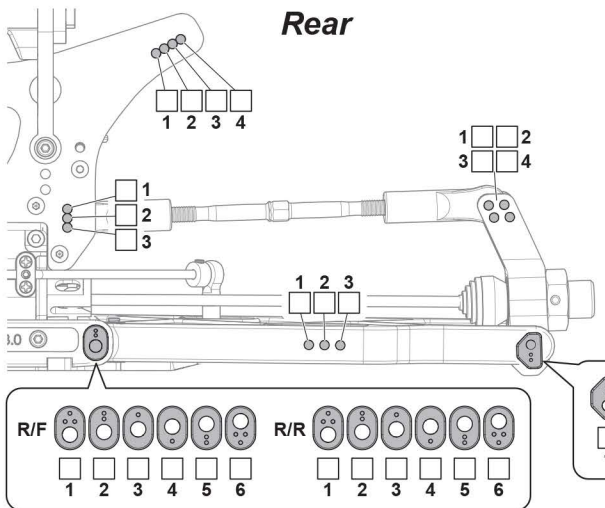

Rear

Wing Brand _____

Wing Model _____

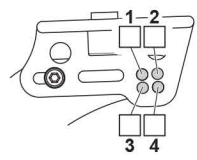

Ride Height _____ mm

Camber Angle _____ °

Sway Bar _____ mm

Shock Length _____ mm

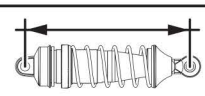

Rear Shocks

Oil weight _____ wt

Piston _____ mm

Bladder _____

Spring _____

Notes

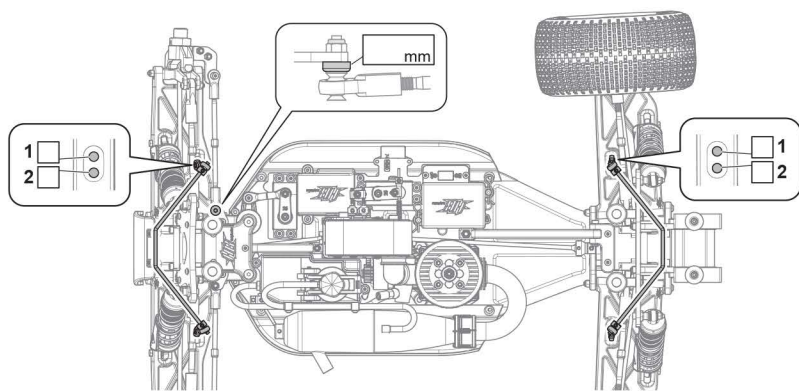

Engine

Brand _____

Spur gear _____ Clutch Bell _____

Clutch Shoes _____

Clutch Springs _____

Glow Plug _____

Glow Fuel _____

Tires	Front	Rear
Brand	_____	_____
Compound	_____	_____
Insert	_____	_____
Wheel	_____	_____
Notes	_____	_____

Notes

Diff Oils

	Front	Center	Rear
Brand	_____	_____	_____
Oil Weight / Grade	_____	_____	_____